

HiFly

Airbus A380-800

CARGO FLIGHTS

9H-MIP



Max
Range
13.300 km



Volume
Capacity
297,86 m³



Max Takeoff
Capacity
569.000 Kg



UD Section

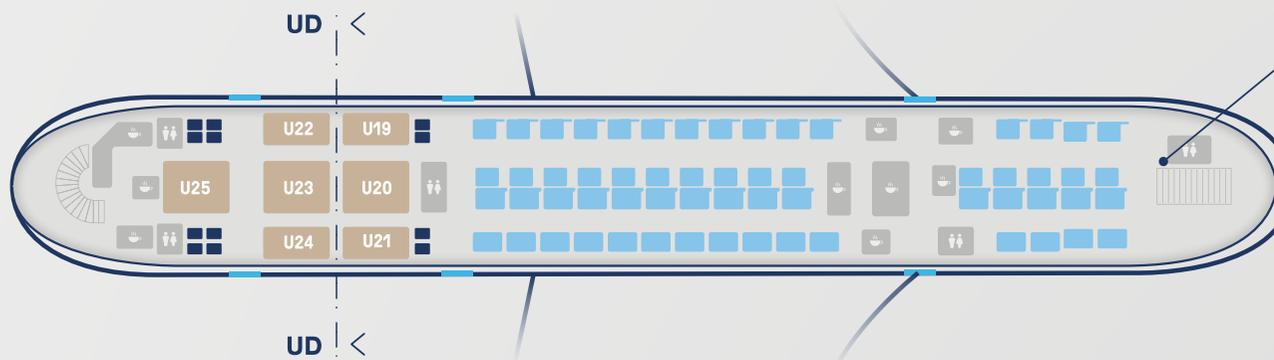
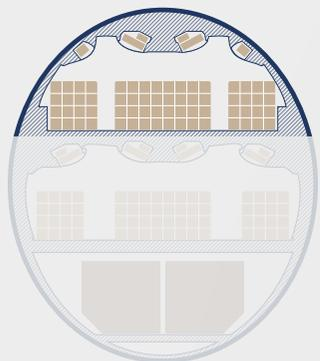

BOXES

TYPE	DIMENSIONS (mm)	TOTAL QUANTITY
A	400 x 400 x 300	2540
B	400 x 270 x 200	1222
D	600 x 500 x 200	144
E	300 x 500 x 170	169
F	300 x 500 x 250	88

VOLUME (m³)

OHSC*	FLOOR	TOTAL
16.25	148.32	164.56

* Overhead Stowage Compartment

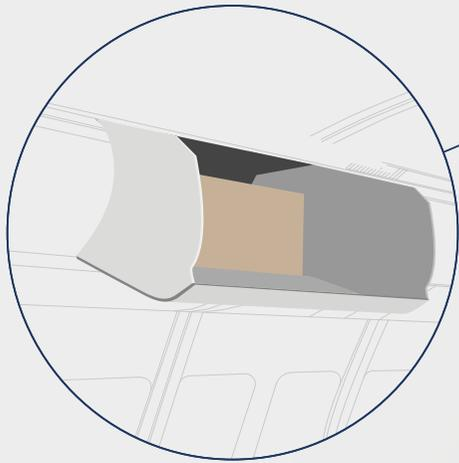

OHSC*

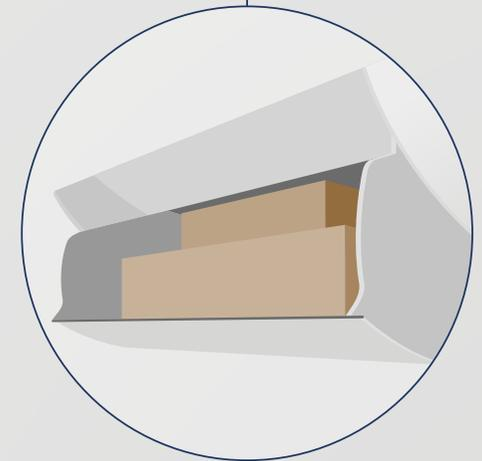
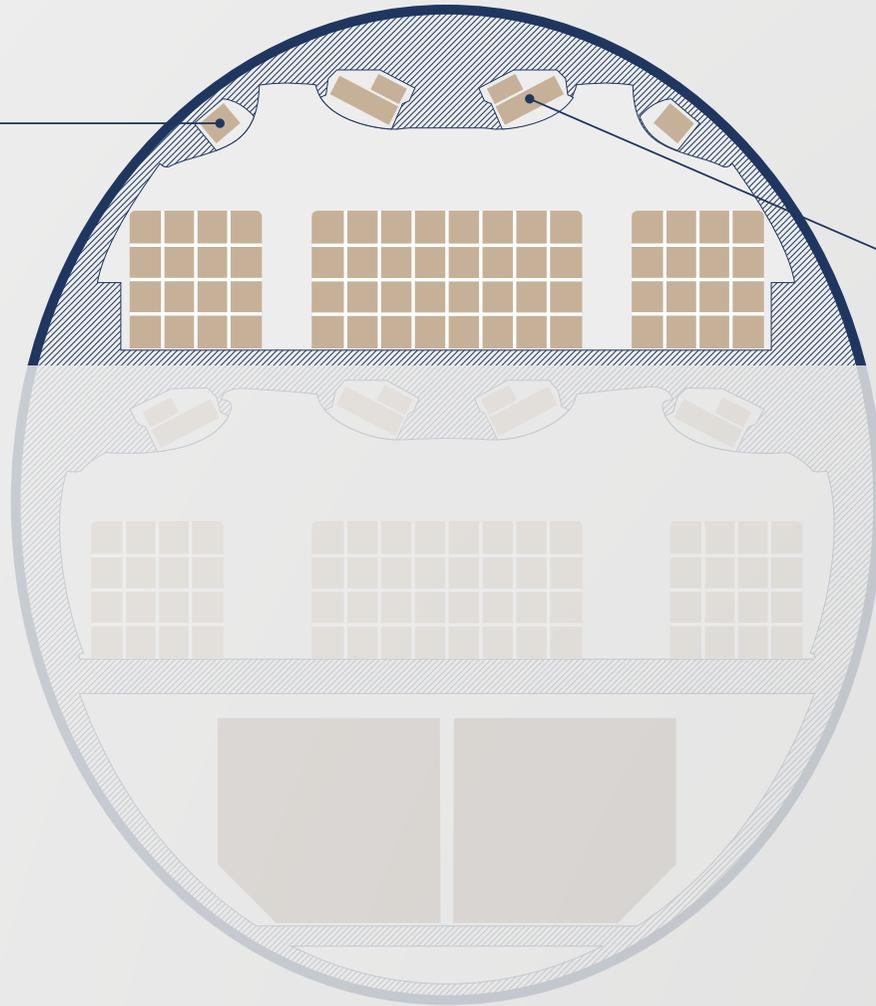

OHSC*

* Overhead Stowage Compartment



MD Section

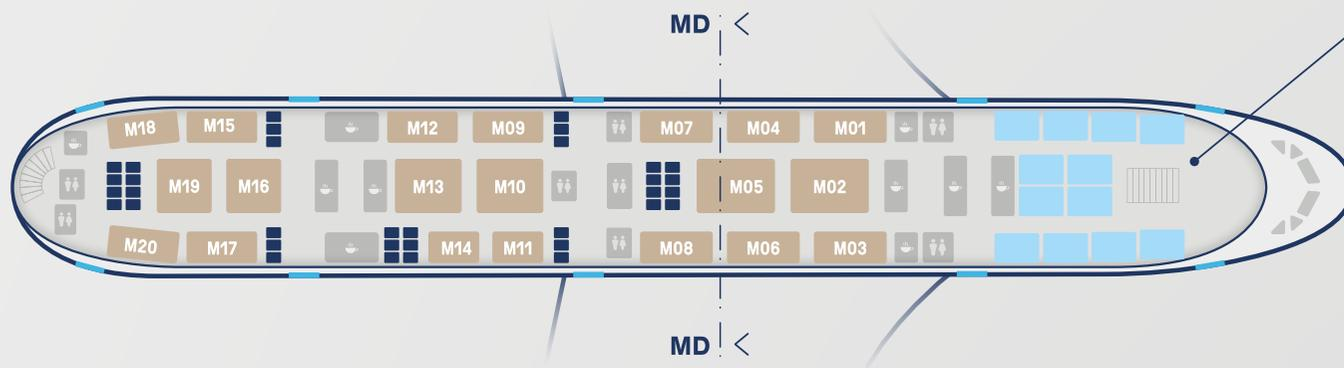
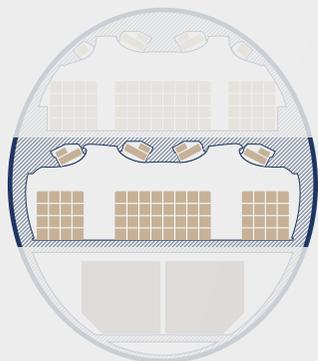

BOXES

TYPE	DIMENSIONS (mm)	TOTAL QUANTITY
A	400 x 400 x 300	2540
B	400 x 270 x 200	1222
D	600 x 500 x 200	144
E	300 x 500 x 170	169
F	300 x 500 x 250	88

VOLUME (m³)

OHSC*	FLOOR	TOTAL
16.25	148.32	164.56

* Overhead Stowage Compartment

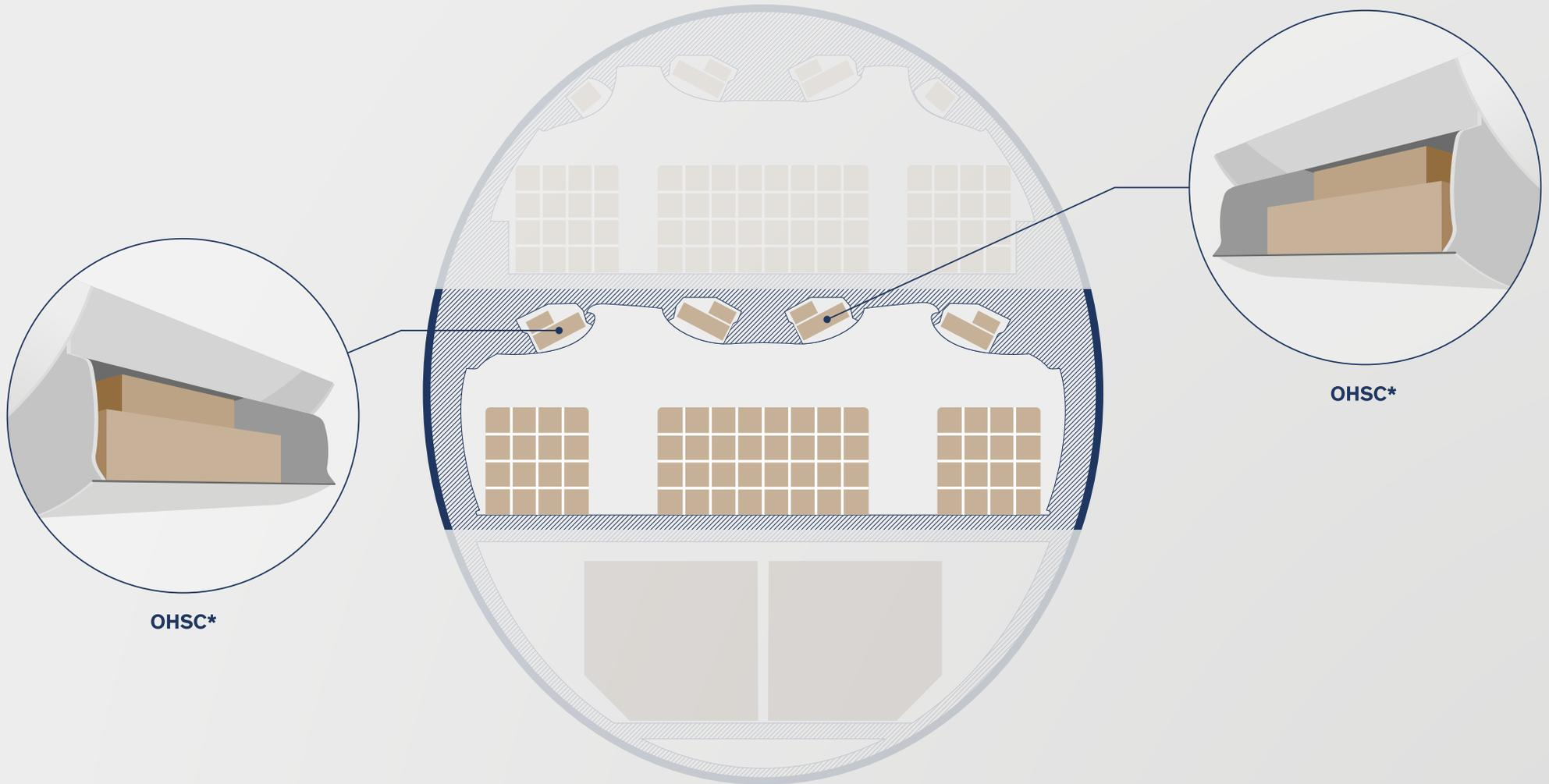

* Overhead Stowage Compartment

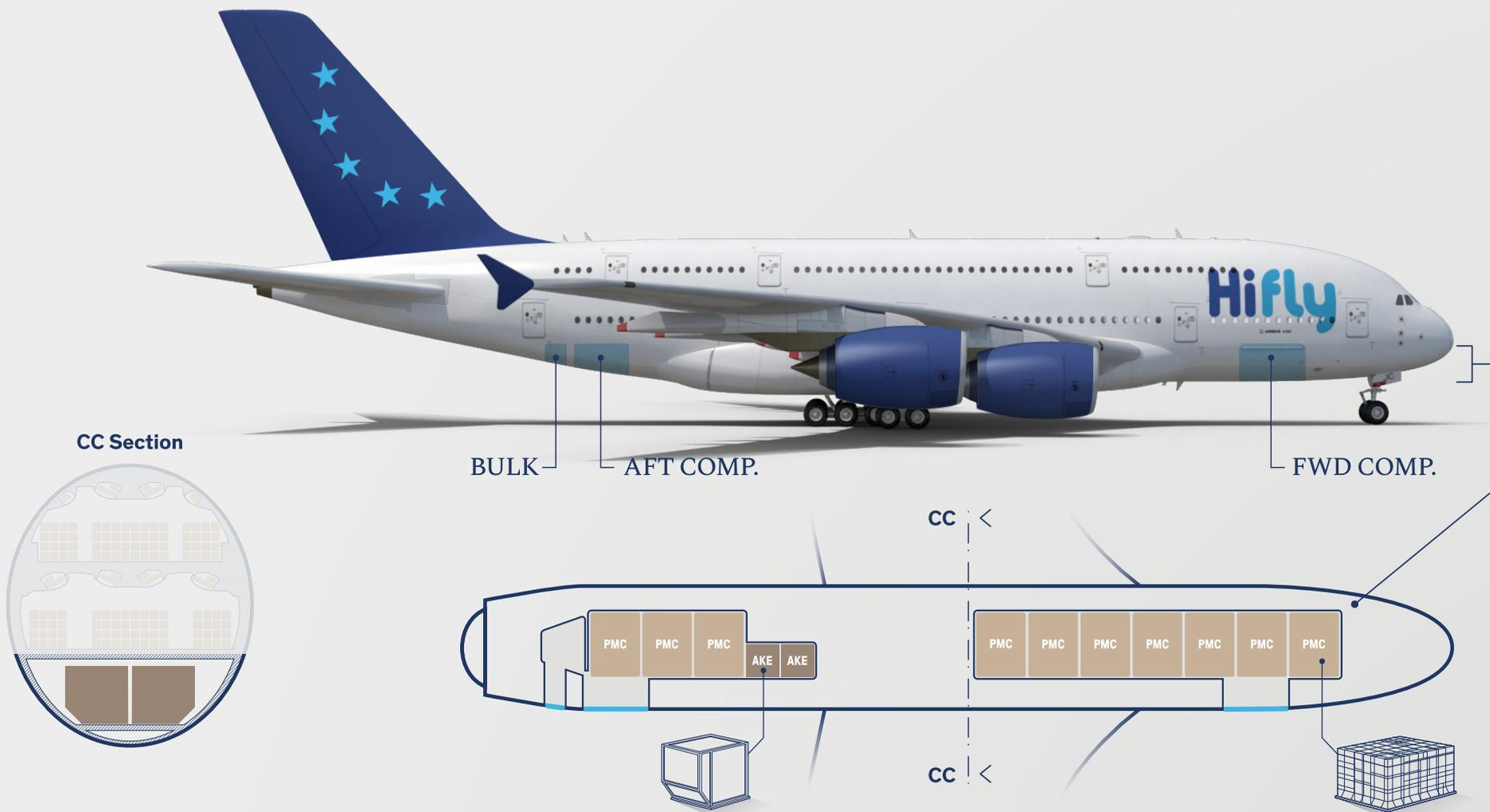

FWD COMP.	AFT COMP.	BULK	TOTAL CARGO (m ³)	ULD'S	
77	42	14.3	133.3	10PMC + 2AKE	Without FAK and TOWBAR

DISCLAIMER

The volume mentioned in this document for the different areas and compartments are for illustration purposes only and do not constitute any kind of guarantee or covenant that such volume can be used in full. Box size, shape and weight can significantly reduce the cargo volume possible to transport on this aircraft. Furthermore, to support the aircraft maintenance and operation, on most flights the carrier might need to carry one or two AKE containers and/or PMC pallet with spare parts, tow bar, tools and consumables. This will further reduce the space available for cargo. The price quoted for your flight does not depend on the actual volume carried.

CARGO COMPARTMENT SECTION

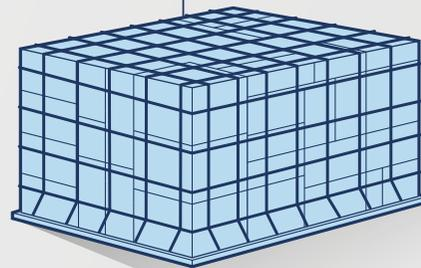
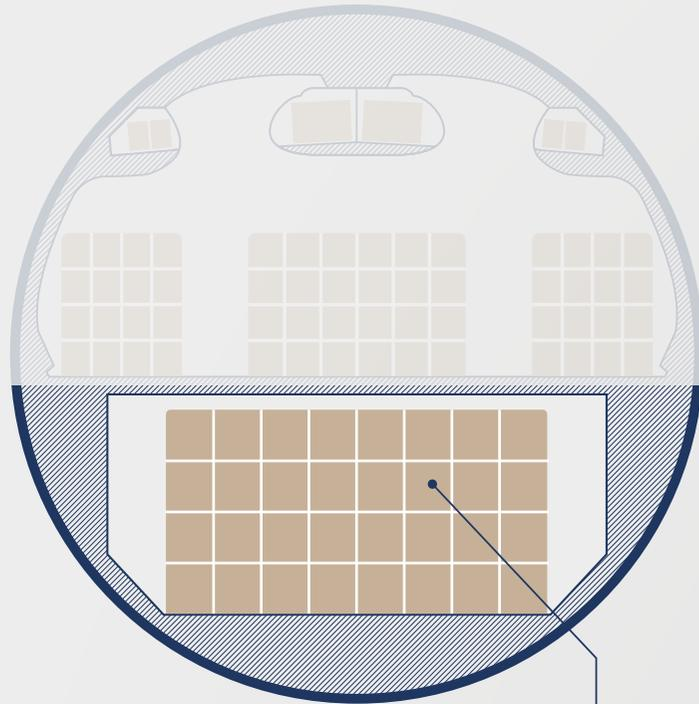

P6P-PMC

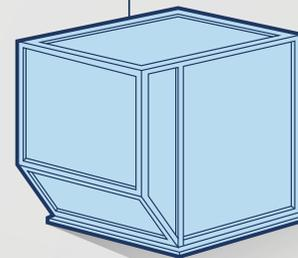
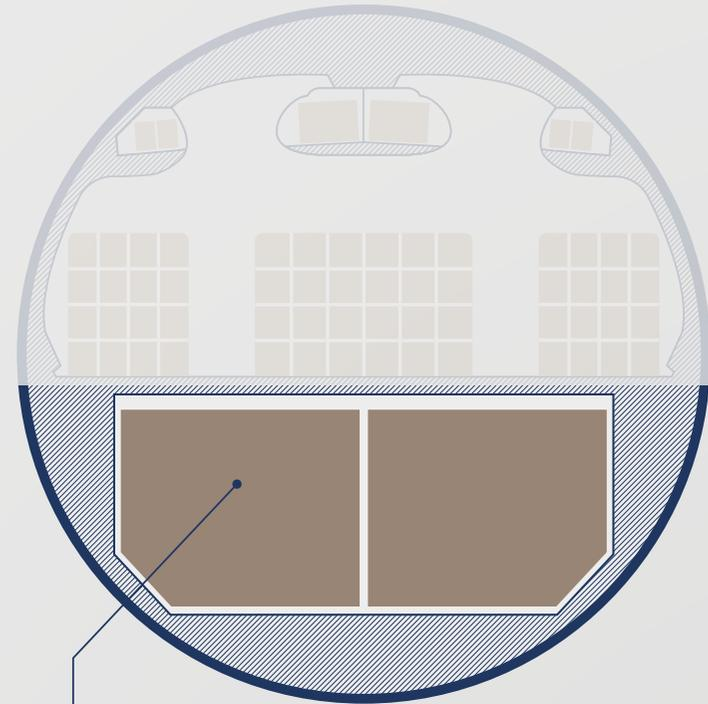

AKE-LD3

AKE-LD3

Internal Volume	4,5 m ³
Max Weight	1560 kg

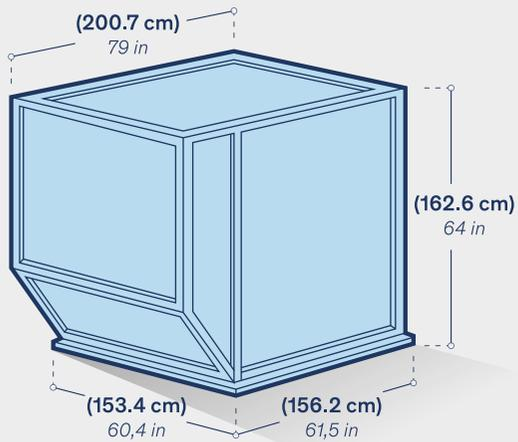

P6P-PMC

Internal Volume	11 m ³
Max Weight	5100 kg

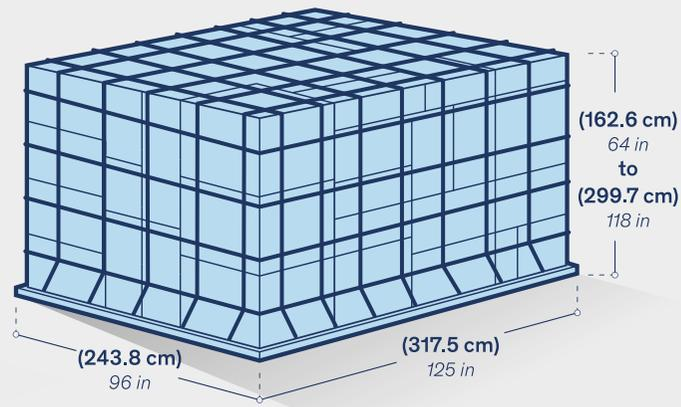

P1P-PAG

Internal Volume	10 m ³
Max Weight	4636 kg

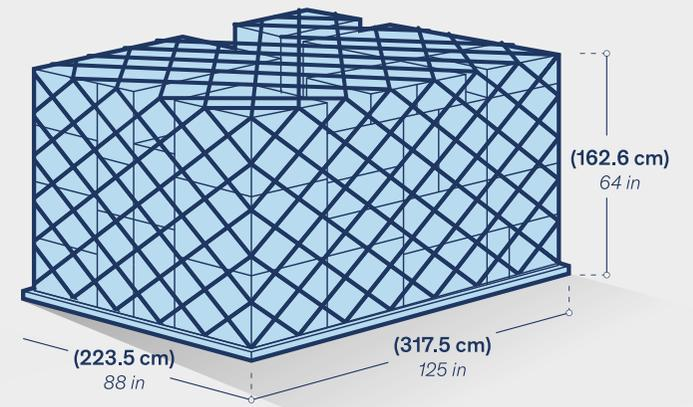



Hi Fly

LOCATION & FACILITIES

Hi Fly headquarters are conveniently located in the center of Lisbon, next to the Sheraton Hotel and just 15 minutes away from Lisbon's International Airport.

ADDRESS

Latino Coelho nr 1, Hi Fly Building
1050-132 Lisbon - Portugal

PHONE

+351 211 143 680
+351 211 143 510 (H24)

E-MAIL

cargo@hifly.aero
cco@hifly.aero (H24)
